

## Thrif-T Luber Low-Pressure Orifice Lubrication System

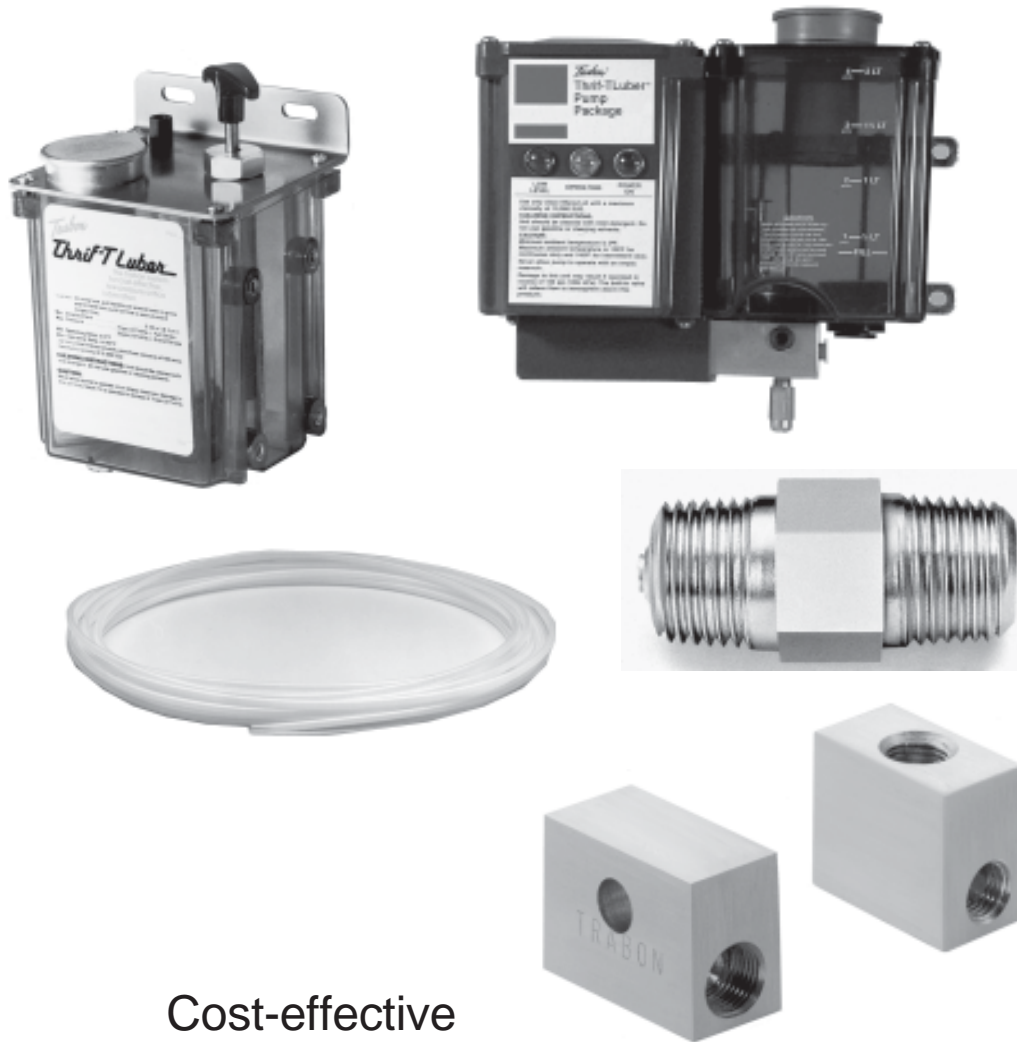

### Cost-effective Low-Pressure Orifice Lubrication System

- For new equipment or replacement of any existing low-pressure orifice system
- Simple, versatile, reliable
- With sales/parts/service - worldwide



**TABLE OF CONTENTS**

Section/Para	Page
1 Introduction / Components / Features .....	1
2 System Operation .....	2
3 Hand Operated Pump .....	3 & 4
4 Electric Motor Driven Pump .....	4 & 5
5 Orifice Meters .....	6 & 7
6 Filter .....	8
7 Tubing and Tube Clips .....	8
8 Manifolds, Anchor Blocks and Tube Fittings .....	9
9 System Design .....	10 - 15
10 Index .....	16



## INTRODUCTION

### FEATURES/BENEFITS

Thrif-T Luber Orifice Systems offer an efficient method of applying lubricant, resulting in less machine downtime, increased productivity, and a safer work environment. Thrif-T Luber Systems go beyond these advantages to provide:

- Easy system design and modification.
- Inexpensive components and installation.
- Fast payback! Savings in lube maintenance; man-hours usually pays for the system within the first year.
- Manual or Electric pumps available to fit a wide variety of applications.
- Both Manual and Electric pumps feature adjustable outputs. This allow two pumps to service small to large systems.
- Orifice fittings have only one moving part and it flexes rather than moves.
- Sintered bronze filters will not shred or clog as can happen with felt filters.



### SYSTEM DESCRIPTION

The Thrif-T Luber Orifice System is a single line resistance type. When the timer, controller, or operator activates the pump, lubricant is forced down a single main line to manifolds, and from there through individual orifice fittings and lines to the lube points. If lube point mounted orifice fittings are used, tee fittings and manifolds are used to provide multiple branch lines that are then connected to the orifice fittings.

Thrif-T Luber Orifice Systems utilize one of two types of pumps. A single stroke hand operated pump, where the stroke length and frequency determine the lube delivery volume to the system, or an electric gear motor driven pump where the pump running time and frequency as established by the built in timer, a remote timer, or the machine PLC determine the volume of lubricant delivered to the system. In either case, the individual orifice fittings proportion pump flow to the individual lube points. Various accessories are available to simplify installation. An optional pressure gauge may be added to monitor pump operation.

### SYSTEM COMPONENTS

#### Pumps

One hand-operated pump and one electric motor driven pump, each with a 1/2 gallon plastic reservoir, and adjustable output, allow the system to be designed precisely for the applications needs.

#### Timer

The built in Solid State Timer can be set to control pump run duration and initiate lube intervals from 30 seconds to 32 hours. Where desired, optional remote timers, can be used to control the lube interval and pump run time.

#### Manifolds and Orifice Fittings

One manifold can be used to distribute lubricant to as many as nine (9) lube points. Orifice Fittings come in three (3) types and ten (10) flow ranges to meet various lube requirements. Bearing point Orifice Fittings are fed directly from the pump through individual branch lines.

#### Tubing, Fittings and Accessories

Thrif-T Luber Orifice Systems utilize 4mm (5/32 inch) nylon tubing and brass fittings to connect the system components. Accessories such as the line filter and pressure gauge enhance reliability and provide the user with a method to monitor pump operation.

### SYSTEM OPERATION

As shown in Figure 1, when the operator actuates the handle, or when the electric motor receives a signal from the timer, the pump is activated. The pump dispenses lubricant either into the mainline tubing which distributes the lubricant to the manifolds, feeding each Orifice Fitting or lines supplying bearing point Orifice Fittings. Each Orifice Fitting is sized to dispense the proper amount of lubricant based on the requirements of the bearing. Details of the operation of each component are included in this bulletin.

### Interchangeability

Trabon components are functionally interchangeable with other commonly used single-line, resistance (orifice) systems. Mounting dimensions of the components are very close to those of other systems, and for some components there is a direct interchangeability in form and fit as well as function.

### Applications

Trabon Thrif-T Luber Systems are ideal for small to medium size machine tools and other equipment requiring economical, intermittent, oil lubrication.

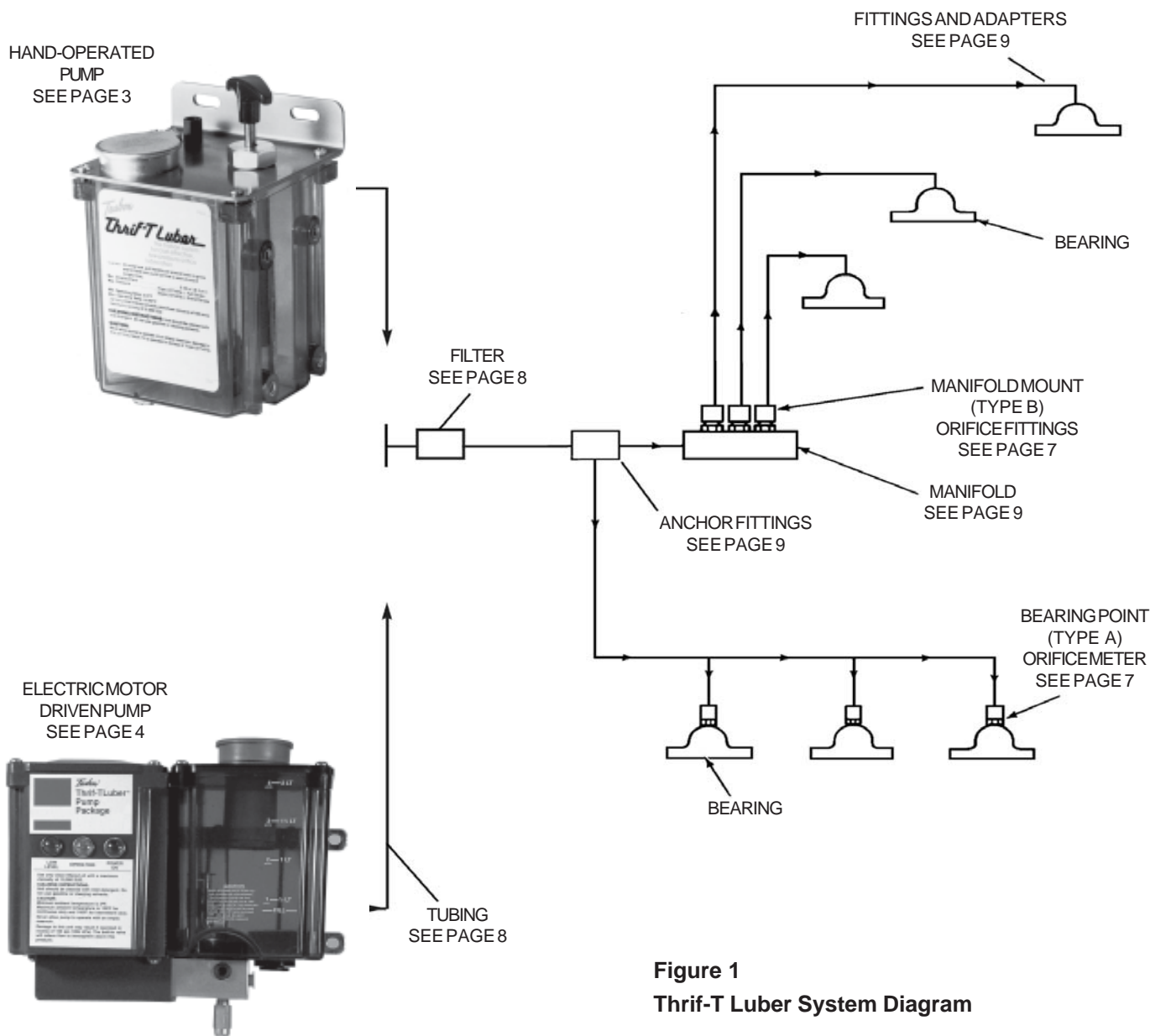

Figure 1  
Thrif-T Luber System Diagram

## Thrif-T Luber Manual Pump

### DESCRIPTION/OPERATION

The Thrif-T Luber Manual Pump (Fig 2) is a positive displacement single stroke pump that delivers 8.2 cc (0.50 cu.in.) of oil per stroke, or 3.6 cc (0.22 cu.in.) per stroke.

As the pump handle is pulled up, the return spring is compressed and the inlet check ball unseats allowing oil to enter and fill the piston chamber. When the handle is released, the return spring drives the piston down, the inlet check ball re-seats and oil is forced out of the pump outlet and through the connecting lines and orifice fittings (not shown) to the friction surfaces on the machine.

### SPECIFICATIONS

Pump output .....Factory set— 8.2 cm<sup>3</sup>/stroke (0.5 cu in.)

Lubricant viscosity limits..... Minimum, 100 SUS  
Maximum, 10,000 SUS

**Note: System is designed only for oil lubrication.**

Reservoir capacity: ..... 1.89 liters (1/2 gallon),  
1,890 cm<sup>3</sup> (116 cu. in.)

Operating temperatures ..... Minimum, -17.8° C (0° F)  
Maximum, 60° C 140° F

Maximum operating pressure ..... 5 bar (75 psi)

### GENERAL INSTRUCTIONS

- Fill reservoir with clean, filtered oil. Never allow the pump to operate on an empty reservoir. Minimum oil viscosity is 100 SUS, maximum is 10,000 SUS.
- Maximum pump pressure is 75 psi at full stroke, 20 psi at end of stroke.
- To drain reservoir, remove the rubber plug from the bottom of the reservoir.
- Cleaning should be done with a mild detergent.

**Do not use gasoline or cleaning solvents.**

### HOW TO ORDER

To order the Thrif-T Luber Manual Pump, TLMP-00 specify part number **384-000-000**. To order pumps without reservoir, consult the factory.



Figure 2

### DIMENSIONS Inches (mm)

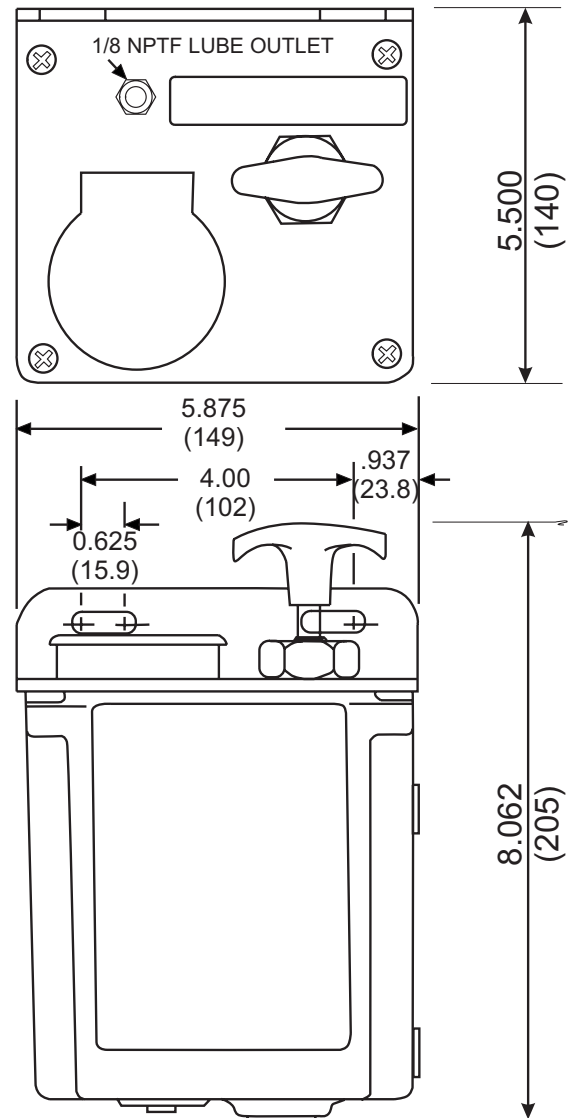

Figure 3

## Thrif-T Luber Manual Pump (Cont'd)

### PUMP STROKE ADJUSTMENT

The standard Thrif-T Luber Manual Pump is factory set for a lube output of 8.2 cc (0.5 cu.in.) per stroke. To determine if the pump output needs to be reduced, multiply the total system volume requirement by the lube interval in hours. Pump output should be equal to, or greater than this amount. If a much lower output is required (44%), lift pump handle (A) to its fully extended position. Remove retaining ring from slot (D) and reinstall in slot (E).

Figure 4

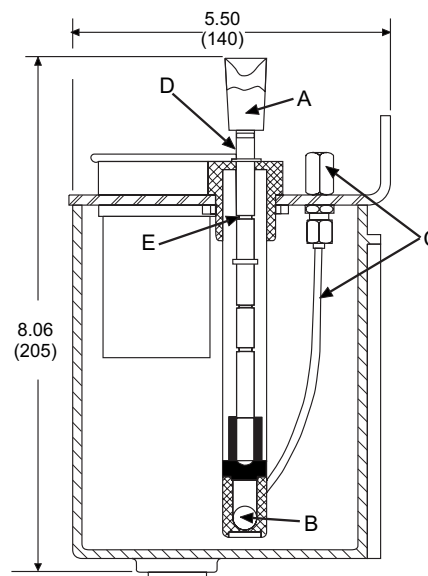

## Thrif-T Luber Electric Pump

### DESCRIPTION

The Thrif-T Luber Electric Pump (Fig. 5) is a positive displacement electric gear motor driven piston pump that delivers .572 cc (0.035 cu.in.) per stroke (6.9 cc 0.42 cu.in.) per minute. It is available with two (2) control options that allow the user to select a model which best suits his needs. The "Time Control" schedules lube frequency in either hours or minutes. The "Remote Control" option allows lube frequency to be scheduled from the machine PLC, or a remote mounted timer.



Figure 5

### HOW TO ORDER

Order the Thrif-T Luber Electric Pump using either the model number or 9-digit part number.

Pump Style	Model No.	Part No
115V Time Control	TLEP-10	521-500-930
115V Remote Control	TLEP-11	521-500-840

#### ACCESSORIES:

Description/Model No.	Part Number
Pressure Gauge : 0-300 psi (0-21 bar) - TLPG-00	493-020-199
Timer Replacement Board	572-142-590
Replacement Relief Valve	508-310-015
Replacement Pump	521-500-720
Replacement Reservoir & Motor Housing	560-002-140
Replacement Gearmotor (115VAC)	521-500-650
Replacement Low Level Switch	541-603-002

### SPECIFICATIONS

- Pump output ..... .572 cm<sup>3</sup> (.035 cu.in.) per stroke  
6.9cc (.42 in<sup>3</sup>/min.)
- For Time Control (at 60 Hz) - adjustable from  
1.14 to 413.03 cm<sup>3</sup>/hr. (.070 to 25.2 in.<sup>3</sup>/hr.)
- Output determined by system control
- Lubricant oil viscosity limits: **(Note: Pump is to be used only with oil.)**
- Minimum ..... 100 SUS
- Maximum ..... 10,000 SUS
- Reservoir capacity 1.89 liters (1/2 gal.), 1,890 cm<sup>3</sup> (116 in.<sup>3</sup>)
- Operating Temperatures:
- Minimum ..... -17.8°C (0°F)
- Max. Continuous ..... 48.8°C (120°F)
- Max. Intermittent ..... (50% duty cycle or less) 60°C (140°F)
- Maximum Operating Pressure ..... 10 bar (150 psi)
- Pump Gearmotors: ..... 115V 50/60 Hz, Shaded pole,  
12 rpm at 60 Hz, 10 rpm at 50 Hz, 0.13 amp running  
current, 0.185 amp inrush current
- Reservoir low-level switch ..... 115V - 10 watt load

Thrif-T Luber Electric Pump (Cont'd)

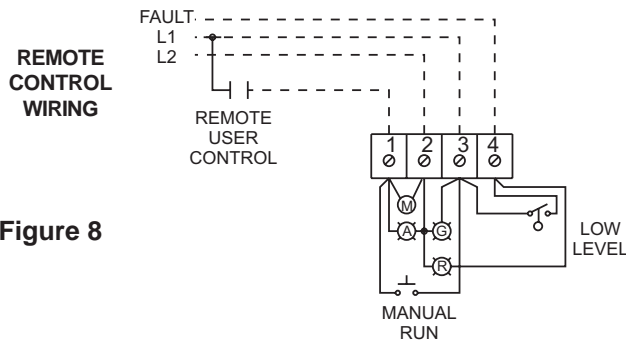
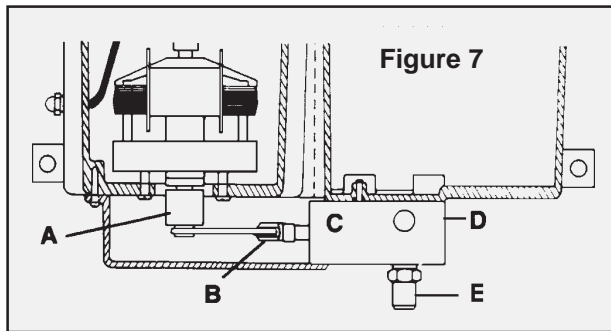
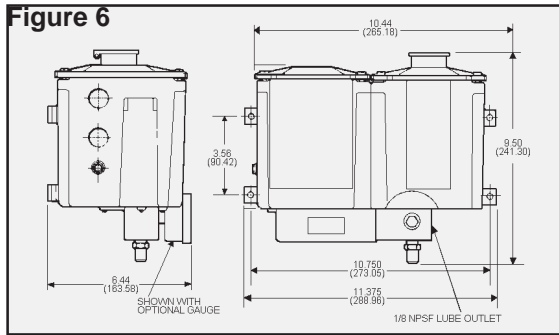

Figure 8

OPERATION

The electric gearmotor drives an eccentric (A) which reciprocates the piston (B) in the pump body (C). The lubricant is discharged past an internal check valve through the outlet (D). If lube system pressure exceeds 10 bar (150 psi), the relief valve (E) automatically opens.

INSTALLATION

**Connecting the pump for Remote Control using the machine "PC" or some other external control** - Input power may be brought into the pump through either of the conduit holes on the left side of the motor compartment. Subsequent electrical connection directions are provided above. When these connections are made, the pump motor's "On time" or output will be determined by the machine or external system control.

For 60 Hz service, pump output will be 6.9 cm<sup>3</sup> (.420 in.<sup>3</sup>) per minute; on 50 Hz, it will be 5.7 cm<sup>3</sup> (.350 in.<sup>3</sup>) per minute. For most applications, we recommend that the pump operate a minimum of one stroke (five seconds "On") per lubrication cycle. When in doubt, consult the factory.

TIME CONTROL WIRING

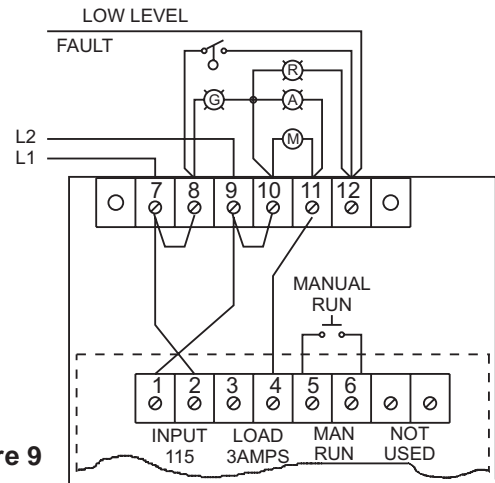

Figure 9

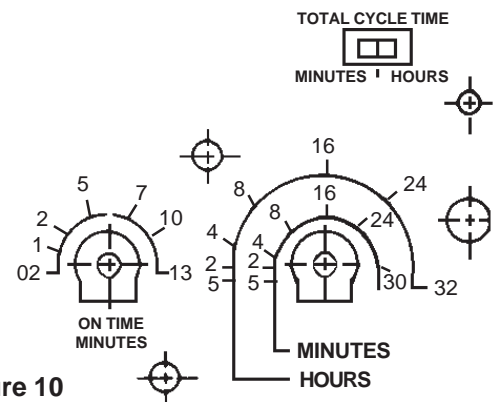

Figure 10

Connecting the pump for Time Control -

Set the slide switch to either minutes or hours for cycle time. Next, set the desired pump "On time" using a screwdriver in the slotted head of the scale marked "On time minutes". Then in a similar fashion, set the specific interval at which lube cycles are to occur using the appropriate scale under "total cycle time".

To find "On time" in minutes = Total Output Required Per Cycle Time (cu.in.) divided by .42 (60 Hz) or .35 (50 Hz).

When power is applied, the timer activates the lube pump motor and simultaneously begins timing of the "On time" and "Total cycle time".

When the "On time" is completed, the timer shuts off the pump motor but continues timing the "total cycle time" until the next cycle and "On time".

Activation of the manual run button resets the cycle time to zero and starts a lube cycle.

Input power may be brought in to the terminal strip through either of two conduit holes on the left side of the compartment. Subsequent electrical connection directions are provided above.

For more details, contact your Thrif-T Luber System distributor or the factory.

## Thrif-T Luber Orifices

### DESCRIPTION/OPERATION

The Thrif-T Luber Orifice Fittings are available in three (3) configurations and 10 size ranges. Each size (5/0 is smallest, 5 is largest) passes twice as much flow as the size below it. Each is equipped with a sintered bronze filter, tapered spiral orifice pin and built in check valve. The sintered bronze filter and tapered spiral orifice pin makes the units more resistant to blockage from contamination than the designs used by competitive units.

When oil from the pump reaches the elastomeric ring that functions as a check valve, the ring flexes in the direction of flow as a result of pressure 0.1 bar (2 psi cracking pressure). When pump flow stops, the ring resumes its original shape and blocks back flow toward the pump. The spiral groove in the tapered pin is used to accurately meter the volume of oil delivered to each bearing.

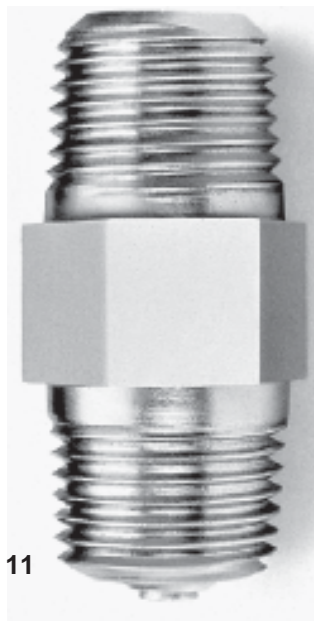

Figure 11

### SPECIFICATIONS

**Material:**

Body and Orifice Pin .....	Brass
Check Valve Disk .....	Buna-N
Filter .....	Sintered Bronze (40 micron)
Lubricant: .....	Oil, 100 SUS to 10,000 SUS
Temperature: .....	0 TO -18 to 82°C (180°F)
Pressure: .....	10 bar (150 psi)

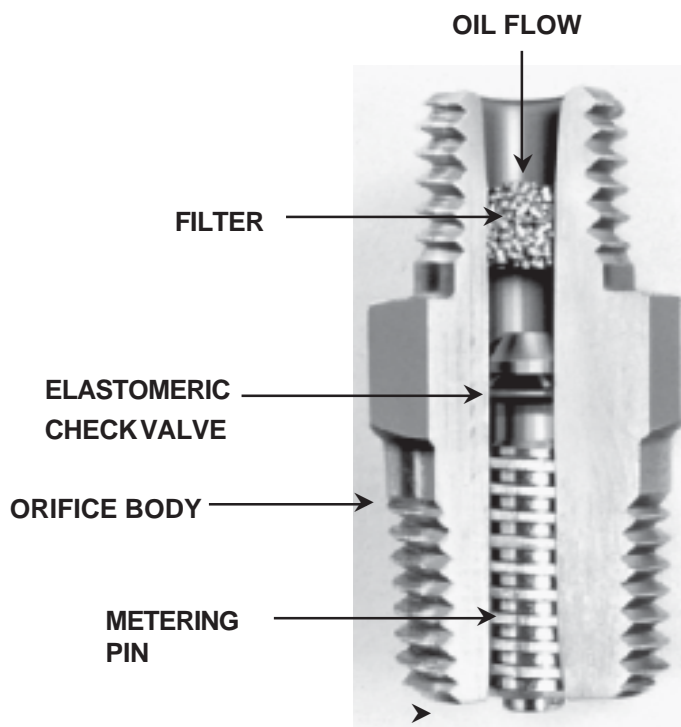

Figure 12

### Thrif-T Luber Orifices (Cont'd)

**3 configurations, 10 sizes in each, cover a wide range of design and/or retrofit requirements.**

### DIMENSIONS mm (Inches)

#### Type A:

This configuration is used when the orifice (metering unit) is mounted directly at the bearing point, at the end of the pressure line.

SIZE	ORDER	PART NO.
5/0	TLOA-50	464-010-050
4/0	TLOA-40	464-010-040
3/0	TLOA-30	464-010-030
2/0	TLOA-20	464-010-020
0	TLOA-0	464-010-000
1	TLOA-1	464-010-001
2	TLOA-2	464-010-002
3	TLOA-3	464-010-003
4	TLOA-4	464-010-004
5	TLOA-5	464-010-005

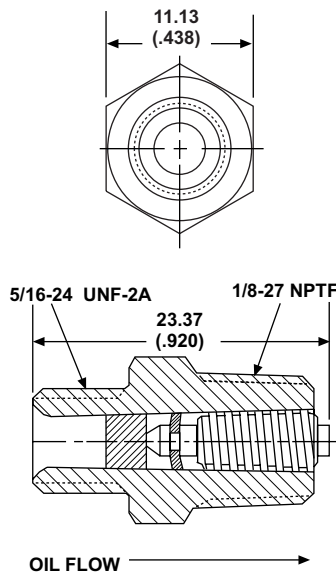

Figure 13

#### Type B:

This configuration is used when the orifice (metering unit) is to be mounted into "Tee" heads or manifold bars, and then connected to the bearing point by tubing.

SIZE	ORDER	PART NO.
5/0	TLOB-50	464-030-050
4/0	TLOB-40	464-030-040
3/0	TLOB-30	464-030-030
2/0	TLOB-20	464-030-020
0	TLOB-0	464-030-000
1	TLOB-1	464-030-001
2	TLOB-2	464-030-002
3	TLOB-3	464-030-003
4	TLOB-4	464-030-004
5	TLOB-5	464-030-005

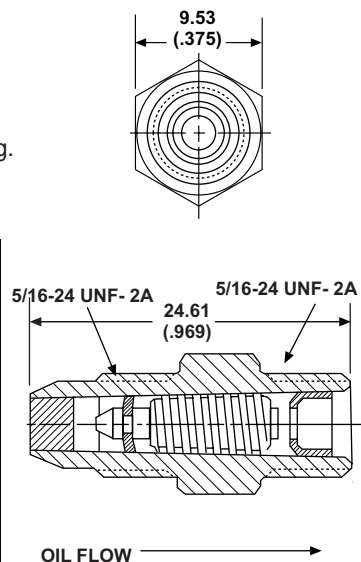

Figure 14

#### Type C:

This configuration is used when the orifice (metering unit) is to be mounted directly at the bearing point, and used in conjunction with a "Tee" head to provide for two or more tube connections.

SIZE	ORDER	PART NO.
5/0	TLOC-50	464-020-050
4/0	TLOC-40	464-020-040
3/0	TLOC-30	464-020-030
2/0	TLOC-20	464-020-020
0	TLOC-0	464-020-000
1	TLOC-1	464-020-001
2	TLOC-2	464-020-002
3	TLOC-3	464-020-003
4	TLOC-4	464-020-004
5	TLOC-5	464-020-005

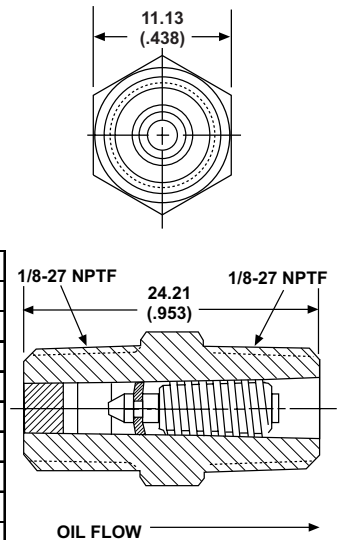

Figure 15

### HOW TO ORDER

Order Thrif-T Luber orifices using the nine digit Part Number shown with the specific fitting type and size.

### Thrif-T Luber Accessories & Hardware

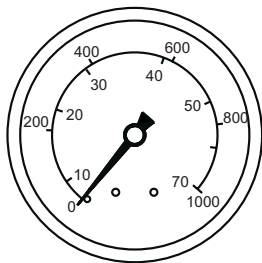

Figure 16

**Pressure Gauge** for use with Thrif-T Luber Electric Pump has plastic case with 50.8 mm (2-in.) diameter dial and 0 to 21 bar (0 to 300 psi) range. Has 1/4-18 NPTF center back mount.

**Model:** TLPG-00. Part No. **493-020-199**.

**Tube Clips**—Standard clips for 1, 2, 3, or 4 tubes are plated steel. Four sizes.

Part No. **435-710-XXX**  
See below chart

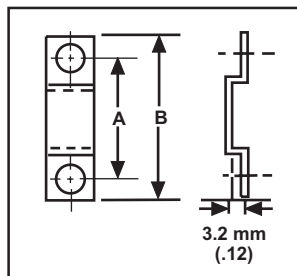
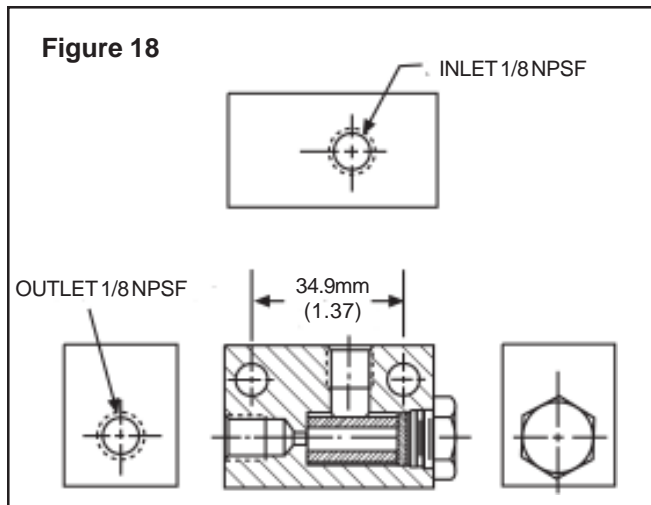

Figure 17

No. of Tubes	Dim. A In (mm)	Dim. B In (mm)	Model:	Part Number
1	—	.62 (46.0)	TLTC-01	435-710-010
2	.81 (20.6)	1.22 (31.0)	TLTC-02	435-710-020
3	.94 (23.8)	1.31 (33.3)	TLTC-03	435-710-030
4	1.06 (27.0)	1.44 (36.5)	TLTC-04	435-710-040



**In-Line Filter** - Helps keep contaminants that get past the pump's screen/strainer from clogging orifice filters. Comes complete with filter body, 25-micron filter element, gaskets and closure plug. Measures 52.4 mm (2.06 in.) long, 25.4 mm (1.00 in.) deep and 31.8 mm (1.25 in.) high.

**Model:** TLLF-00. Part No. **473-000-232**.

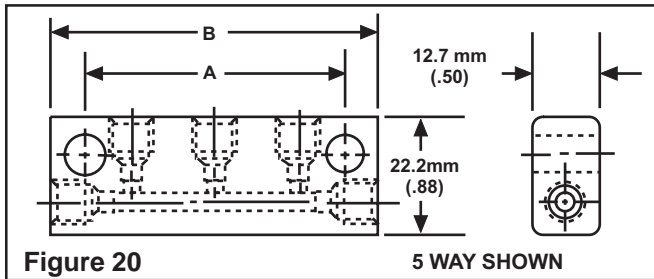

Figure 19

**Nylon Tube**—Has 4 mm (5/32-in.) O.D., and is burst rated at 69 bar (1000 psi). Comes in 7.62 m (25 ft.) coiled lengths.

**Model:** TLTP-25. Part No. **400-132-060**.

### Thrif-T Luber Accessories & Hardware (Cont'd)



**Manifold Bars**—Have tapped 5/16-in. holes for 4 mm (5/32-in.) tubing connections. Four sizes.

**Part No. 482-000-XXX**  
See below chart.

No. of Ports*	Dim. A		Dim. B		Model	Part Number
	mm	(In)	mm	(In)		
4	33.3	(1.31)	46.0	(1.81)	TLMB-04	482-000-351
6	65.1	(2.56)	77.8	(3.06)	TLMB-06	482-000-353
8	96.8	(3.81)	109.5	(4.31)	TLMB-08	482-000-355
10	128.6	(5.06)	141.3	(5.56)	TLMB-10	482-000-657

\*One port must be used for inlet.

**Anchor Block**—Can also serve as a two-way manifold bar with 4 mm (5/32-in.) tube connection to 1/8 in. female pipe. Measures 28.4 x 15.9 x 25.4 mm (1.19 x 0.62 x 1.00 inches).

**Model:** TLAB-00.  
**Part No. 482-000-348.**



**Tee Fitting**—For use with two 4 mm (5/32-in.) tube outlets and 1/8-in. pipe. Measures 28.4 x 25.4 x 15.9 mm (1.12 x 1.00 x 0.62 inches).

**Model:** TLTF-00.  
**Part No. 482-000-347.**

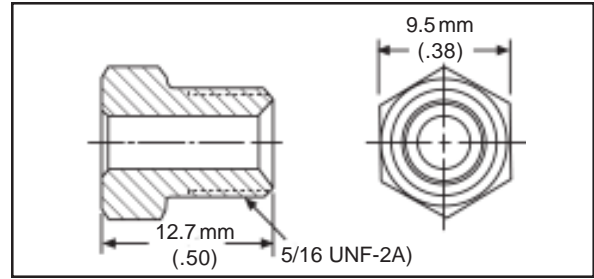

**Inverted Nut**—Brass tube nut to attach 4 mm (5/32-in.) tube to manifold

**Model:** TLIF-00.  
**Part No. 435-702-268.**

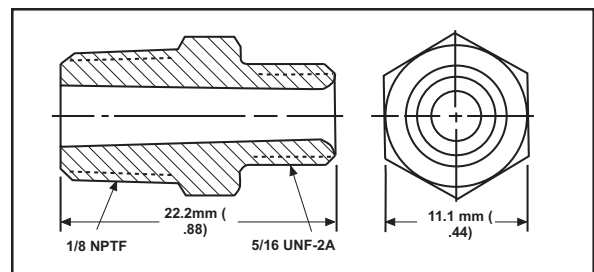

**Bearing Fitting**—Used in 1/8 NPT bearing tap or manifold to attach 4 mm (5/32-in.) tubing.

**Model:** TLBF-00. **Part No. 464-100-100.**



**Compression Nut**  
—Brass tube nut for bearing fitting with 5/16-24 thread for 4 mm (5/32-in.) tubing.

**Model:** TLCN-00.  
**Part No. 435-390-070.**



**Compression Sleeve**—For 4 mm (5/32-in.) tubing.

**Model:** TLCF-00.  
**Part No. 435-380-080.**

**Note:** Can be used with inverted nut, or bearing fitting.

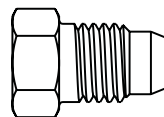

**Closure Plug** —Has 7.9 mm (5/16-in.) UNF-2A full thread to within 1.6 mm (0.06-in.) of hex head.

**Model:** TLCP-00.  
**Part No. 435-702-267.**

**Note:** Used to plug unwanted manifold ports.

# System Design & Component Selection

## Guide to System Design & Component Selection for low-pressure, orifice type lubrication systems.

**NOTE:** In using this guide, you will be referring to Design Charts shown on page fourteen (14). Additional copies of Design Chart A are available from your Thrif-T Luber distributor or by contacting Lubriquip.

**STEP ONE: All bearing data should be recorded on a copy of Design Chart A.**

- Note bearing name or location in column 1.
- List bearing size in column 2A and bearing type in column 2B.
- List the lube taps per bearing in column 3.

**STEP TWO: Calculate hourly bearing lube replacement requirements.**

- Using formulas given in Design Chart B, calculate and enter in column 4.
- Multiply the value in column 4 by the lube factor of three and enter in column 5. This figure is the lube. volume.
- Divide the figure in column 5 by the number of taps (column 3) and enter this figure in column 6. This is the calculated lube volume — cubic inches per hour per tap.

**STEP THREE: Determine lube ratio.**

- Select lowest volume requirement in column 6 and assign base ratio of 1 . Enter in column 7.
- Divide all other volumes in column 6 by the lowest volume requirement (see preceding point). Enter the results as the remaining base ratios, in column 7. Refer to Design Chart C for base ratio combinations. Choose the base ratio number that is closest to your exact calculation result.

**STEP FOUR: Select orifice Size.**

- Determine maximum-to-minimum base ratio number from column 7.
- Locate the appropriate vertical column from Design Chart C. This is done by finding the maximum base ratio from Design Chart C that is nearest in number to the maximum base ratio you have just determined.
- The bearing(s) with the smallest volume requirement becomes the base orifice and is assigned the smallest number in column 1 .
- Using the same vertical column from Design Chart C, select orifice sizes to meet all base ratios in column 7.

**Note:** Select orifice size in same vertical column that is nearest in number to base ratio (when in doubt, use next larger size).

- Enter all orifice sizes in column 8 on Design Chart A.
- Using “flow value” column from Design Chart C, enter each flow value for corresponding orifice size in column 9 of Design Chart A.

**STEP FIVE: Determine system flow value.**

- Multiply each flow value from column 9 by number of taps in column 3. Enter in column 10.
- Add up the total flow values in column 10. Enter at bottom of column 10. This is total system flow value (Q).

**STEP SIX: Make a pump selection.**

— **Manual Pump:**

1. Determine approximate operating oil viscosity (V) from Design Chart E.
2. Divide V by total system flow value (Q) from column 10 of Design Chart A.
3.  $\frac{V}{Q}$  should = 1,000 or less.

If the result exceeds 1,000, use a larger orifice size (5/0 is the smallest and 5 is the largest size in terms of flow) for the base orifice, and re-select all the remaining orifice sizes accordingly, until  $\frac{V}{Q} = 1,000$  or less.

**Example:** if base orifice is "2/0" and V is greater than 1,000, try "0" orifice as base.

— **Electric Pump:**

1. Determine approximate operating viscosity (V) from Design Chart E.
2. Determine total system flow (Q) from column 10 of Design Chart A.
3. Using Design Chart D, plot coordinates of V and Q on chart. If the point falls within shaded area of Chart D, the system is compatible with electric pump.
4. If the coordinates fall above the shaded area (below 20 psi), select base orifice with lower base ratio and re-select all remaining orifice sizes accordingly.

**Example:** If base orifice is "210", try "3/0" orifice. This will double system pressure. Repeat until coordinates fall within shaded area.

5. If the coordinates fall below shaded area (above 150 psi), select base orifice with higher base ratio and reselect remaining orifice sizes accordingly.

**Example:** If base orifice is "2/0", try "0" orifice. This will decrease system pressure by 1/2. Repeat until coordinates fall within shaded area.

6. To assist in pump selection, the actual system pressure can be determined by solving for P in the formula  $P = \frac{F \times V}{Q}$

where: P = System Operating Pressure PSI  
 F = Pump Flow Velocity Rating (.40)  
 V = Viscosity of Oil @ Operating Temp.  
 Q = Total System Flow

### System Design & Component Selection Cont'd

**EXAMPLE: Milling Machine 7200 SUS Oil 60°F Operating Temperature  
Automatic System 24 Lube Points**

#### Bearings:

1. Feed Screw —  
ball screw — 1 .5 pitch dia. x 8 rows, 2 lube points
2. Vertical Slide Drive —  
ball screw — 1 .5 pitch dia. x 8 rows, 2 lube points
3. Vertical Slide —  
9" wide x 18" long, 2 lube points
4. Horizontal Slide —  
9" wide x 18" long, 2 lube points
5. Vertical Slide Ways —  
1 .5" wide x 18" long, 4 lube points
6. Horizontal Slide Ways —  
1.5" wide x 18" long, 4 lube points
7. Spindle —  
2 double-row, anti-friction, 2" shaft dia., 1 lube point on each pair
8. Drive Shaft —  
2 anti-friction, 1.5" shaft dia., 1 lube point each
9. Change Gears —  
4 gears, 4" 1.D. x 3/4" wide, 2 lube points total
10. Motor Drive Shaft —  
1 anti-friction, 1.5" Dia., 1 lube point each

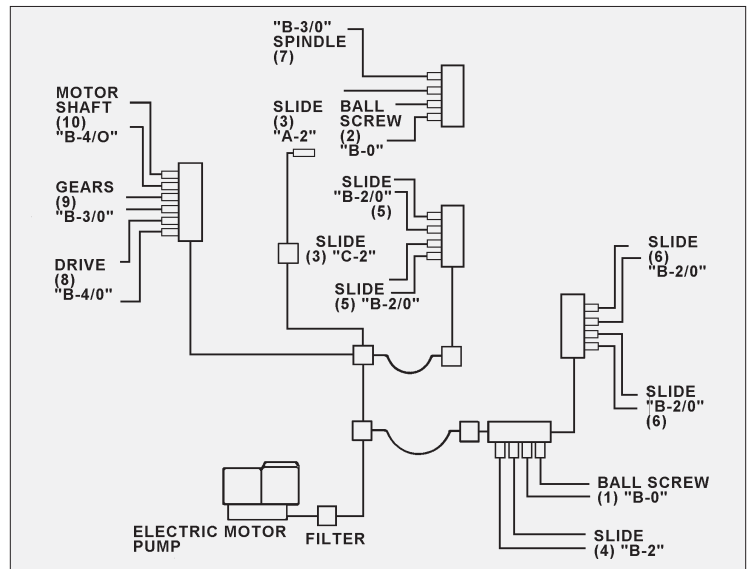

Figure 28

CUSTOMER ABC MACH. TYPE OF SYSTEM: MANUAL  AUTOMATIC  FILE NO. 1001  
 MACHINE OR EQUIPMENT MILLING MACHINE OIL VISCOSITY 7200 OPERATING TEMP. 60 °F. DATE XX/XX/XX  
 PAGE 1 OF 1

REF. NO.	LOCATION OR NAME OF BEARING	BEARING		NO. OF TAPS	BRG. REQ. CU. IN./HR.	FACTOR	LUBE VOLUME CU. IN./HR. (D)	LUBE VOLUME PER TAP (E)	BASE RATIO (C)	ORIFICE SIZE (C)	FLOW VALUE (C)	TOTAL FLOW VALUE
		SIZE (A)	TYPE (B)									
1	Feed Screw	1.5 P.D. X 8 Rows	Ball Screw	2	.038	3	.114	.057	8	3	2.443	4.886
2	Vertical Slide Drive	1.5 P.D. X 8 Row 3	Ball Screw	2	.038	3	.114	.057	8	3	2.443	4.886
3	Vertical Slide	9" x 18"	Slide	2	.162	3	.486	.243	32	5	9.752	19.504
4	Horizontal Slide	9" x 18"	Slide	2	.162	3	.486	.243	32	5	9.752	19.504
5	Vertical Slide	1.5" x 18"	Slide	4	.027	3	.081	.020	4	2	1.219	4.876
6	Horizontal Slide	1.5" x 18"	Slide	4	.027	3	.081	.020	4	2	1.219	4.876
7	Spindle	2" x 2 Rows	R.F.	2	.008	3	.024	.012	2	1	.612	1.224
8	Drive Shaft	1.5" x 1 Row	R.F.	2	.004	3	.012	.006	1	0	.305	.610
9	Change Gears	4" P.D. x 3/4" W	Gear	2	.009	3	.027	.014	2	1	.612	1.224
10	Motor Drive Shaft	1.5" x 1 Row	R.F.	2	.004	3	.012	.006	1	0	.305	.610
11						3						
12						3						
13						3						
14						3						
SYSTEM TOTAL				24	.479 in <sup>3</sup>		1.437 in <sup>3</sup>					62.2

© Registered trademarks of LUBRIQUIP, INC..

(A) DIAMETER AND WIDTH OF CYLINDRICAL BEARINGS — LENGTH AND WIDTH OF SLIDES — SHAFT DIAMETER OF ANTI-FRICTION BEARINGS AND NUMBER OF ROWS.  
 (B) TYPE OF SURFACE — SLIDING, PLAIN OR TYPE OF ANTI-FRICTION BEARING.  
 (C) FROM CHART "C"  
 (D) BEARING REQUIREMENT x NUMBER OF TAPS x FACTOR (B)  
 (E) LUBE SUPPLY VOLUME — NUMBER OF TAPS

P = PRESSURE PSI  
 F = PUMP FLOW  
 V = OIL VISCOSITY  
 Q = TOTAL FLOW VALUE

$$P = \frac{F \times V}{Q}$$

# System Design & Component Selection Cont'd

## Component Selection (Using the example on page 11)

### Orifice Selection

(See page 7 for orifice data and how to order.)

- A. Select orifice size based on flow requirements.
- B. From our example, we would have 24 total lube points. (Bottom of column 3, Design Chart A). They are in five sizes, as follows:

- |   |   |                              |
|---|---|------------------------------|
| <ul style="list-style-type: none"> <li>1. (4) Size "0"</li> <li>2. (4) Size "2"</li> <li>3. (8) Size "2/0"</li> <li>4. (4) Size "3/0"</li> <li>5. (4) Size "4/0"</li> </ul> | } | SEE COLUMN 8, DESIGN CHART A |
|---|---|------------------------------|

- C. Select orifice type based on orifice function.
  - 1. Type "A" Orifice  
These orifices are used when metering unit is mounted directly at the bearing point and at the end of the pressure line.
  - 2. Type "B" Orifice  
These orifices are used when metering unit is mounted into "tee" heads, or junction bars, and then connected to bearing point by 4 mm (5/32 in.) O.D. tubing.
  - 3. Type "C" Orifice  
These orifices are used when metering unit is mounted directly at the bearing point, and used in conjunction with "tee" head to provide for two (2) or more tube connections.

- D. For the example, we would then select:

- 1. (4) Type "TLO-B-O"
- 2. (1) Type "TLO-A-2"
- 3. (2) Type "TLO-B-2"
- 4. (1) Type "TLO-C-2"
- 5. (8) Type "TLO-B-210"
- 6. (4) Type "TLO-B-3/0"
- 7. (4) Type "TLO-B-4/0"

### Pump Selection

(See page 3 thru 5 for pump data and how to order.)

- A. Select Type of pump — Manual or Electric. Consider:
  - Cost
  - Preference
  - Size of System
- B. If manual pump is chosen, select output. Multiply the value in column 5, Chart A (lube volume cu. in./hr.) by number of hours between lube applications. Set pump output equal to or greater than this total.

If, in the example, we were using a manual pump (system is realistically too large for manual pump), the pump output is factory set @ .50 Cu.in./stroke. To lubricate machine twice per shift (every 4 hours), we would multiply 1.437 (total lube volume cu.in./hr) by 4 (hours between lube applications). The result would be 5.748 cu.in. Pump would therefore require 11.5 or 12 full strokes (5.748 req.) every four hours.  
.50 output

- C. If an electric pump is chosen, determine the type control needed.
  - 1. **Remote Control**  
The pump motor would have to be actuated to provide sufficient "On time" to meet total lube volume requirements. Pump output is 6.9 cc (.420 cu.in.) per minute at 60 Hz and 5.77 cc (.350 cu.in.) per minute at 50 Hz.

In our example, at 60 Hz the pump would have to be actuated to run 3.4 minutes per hour:  
(1.437 lube req.)  
.420 output

- 2. **Time Control**  
Set volume control of the pump to the total system requirement.

In the example, we chose the Time Control Pump. The timer would be set at 3.42 minutes "On time" with one hour cycle time at 60 Hz which would delivery 1.437 cubic inches.

### Accessories

(See page 8 and 9 for accessory data and how to order.)

#### Select as required:

- Gauge (Electric Pump)
- In-Line Filter (Electric Pump)
- Anchor Blocks
- Fittings
- Manifold Bars
- Tube Clips
- Tubing

## System Design & Component Solution

### Plumbing —

Lubricant flow velocity within this system is relatively low. To assure accurate proportioning through the various orifices in the system, it's important that velocity remain low. Significant pressure drop through long delivery lines may affect the volume of oil delivered by the orifice fitting at the end of that line.

For general application, 4 mm (5/32 in.) tubing is recommended. Where applicable this tubing may be:

- 4 mm (5/32 in.) dia. x .64 mm (.025 in.) wall nylon (where flexibility is required)
- 4 mm (5/32 in.) dia. x .51 mm (.020 in.) wall steel tubing
- 4 mm (5/32 in.) dia. x .64 mm (.025 in.) wall copper tubing (where ease of installation is required)
- 3.18 mm (1/8 in.) dia. hose (where movement and flexibility are required).

### Automatic (Electric Pump) Systems —

The selection of the tubing for the main line may affect the orifice selection in an automatic cyclic system which is intended to operate with a pump pressure between 20 and 150 psi. Main line pressure drop may affect the orifice proportioning if the fluid viscosity exceeds 3,000 SUS at operating temperature. Main line pressure drop (psi) should not exceed 15 percent of system pressure. Main line pressure drop may be calculated by first determining the Q value of the line with the following formula:

$$Q = \frac{53,192,000 \times d^4}{L}$$

where: d = inside diameter of the main line  
 L = the length of line (in inches)

For 5/32-in. tubing with .025-in. wall, the formula is:  $Q = 560 \div \text{length of line (in feet)}$

The pressure drop of the line can be determined

by:  $P = \frac{F \times V}{Q}$  where: P = line pressure drop  
 F = pump flow rate (.40 for the Thrif-T Luber Electric Pump)  
 V = viscosity of fluid at operating temperature  
 Q = the flow value of the tubing (see preceding)

When the main line exceeds 10 feet, or the fluid viscosity exceeds 5,000 SUS at operating temperature, consult the factory.

### Prefilling the System —

The system and all of its delivery lines must be filled with oil prior to initial operation of the equipment to be lubricated. Also, the system should be filled after a substantial machine shutdown period. This assures immediate lube supply to the bearings. The prefill volume may be as little as 1.0 cubic inch or as much as 3.0 cubic inches in larger systems.

#### In Thrif-T Luber Electric Pump supplied systems...

Prepriming may require several minutes of pump operation for small systems. Larger systems may require six to eight minutes of pump operation. The manual run button may be used to override the normal pump setting.

The system can be considered adequately preprimed when oil flow is observed at the most remote point of the system, or (if pump has gauge accessory) when gauge pressure reaches the planned pressure level.

#### In Thrif-T Luber Manual Pump supplied systems...

Prefilling may require several operations of the pump handle. The system is adequately preprimed when the pump handle recedes slowly.

Design Chart A:

CUSTOMER \_\_\_\_\_ TYPE OF SYSTEM: MANUAL  AUTOMATIC  FILE NO. \_\_\_\_\_  
 MACHINE OR \_\_\_\_\_ OIL VISCOSITY \_\_\_\_\_ OPERATING TEMP. F° \_\_\_\_\_ DATE \_\_\_\_\_  
 EQUIPMENT \_\_\_\_\_ PAGE \_\_\_\_ OF \_\_\_\_

1 REF. NO.	2 LOCATION OR NAME OF BEARING	BEARING		3 NO. OF TAPS	4 BRG. REQ. CU.IN./HR.	5 FACTOR	6 LUBE VOLUME CU.IN./HR. (D)	7 LUBE VOLUME PER TAP (E)	8 BASE RATIO (C)	9 ORIFICE SIZE (C)	10 FLOW VALUE (C)	TOTAL FLOW VALUE										
		SIZE (A)	TYPE (B)																			
1						3																
2						3																
3						3																
4						3																
5						3																
6						3																
7						3																
8						3																
9						3																
10						3																
11						3																
12						3																
13						3																
14						3																
SYSTEM TOTAL												—	—	—	—	—	—	—	—	—	—	THIS NO. EQUALS Q

(A) DIAMETER WIDTH OF CYLINDRICAL BEARINGS - LENGTH AND WIDTH OF SLIDES - SHAFT DIAMETER OF ANTI-FRICTION BEARINGS AND NUMBER OF ROWS.  
 (B) TYPE OF SURFACE - SLIDING, PLAN OR TYPE OF ANTI-FRICTION BEARING.  
 (C) FROM CHART "C".  
 (D) BEARING REQUIREMENT X NUMBER OF TAPS X FACTOR (5)  
 (E) LUBE SUPPLY VOLUME + NUMBER OF TAPS

P = PRESSURE PSI  
 F = PLUMP FLOW  
 V = OIL VISCOSITY  
 Q = TOTAL FLOW VALUE  
 $P = \frac{F \cdot V}{Q}$

Design Chart B: Suggested Lube Replenishment Guidelines.

The replenishment lube value in cubic inches per hour = Area x .001

Plain Bearing . . . . . Area =  $\pi \times D \times L$   
 D = shaft diameter  
 L = length of bearing

Slide, Gibs and Ways . . . . . A = with x length plus travel

Anti-friction . . . . . Area = shaft diameter<sup>2</sup> x number of rows

Gears (Calculate each gear in train) . . . . . Area =  $\pi \times Pd \times W$   
 PD = pitch diameter  
 W = width of gear

Ball Screw . . . . . Area =  $\pi \times Pd \times$  rows x Travel  
 Pd = pitch diameter of ball race  
 Rows = number of rows in engagement with shaft

NOTE:  $\pi = 3.14$

Design Chart D: For Selectin of Automatic Pumps

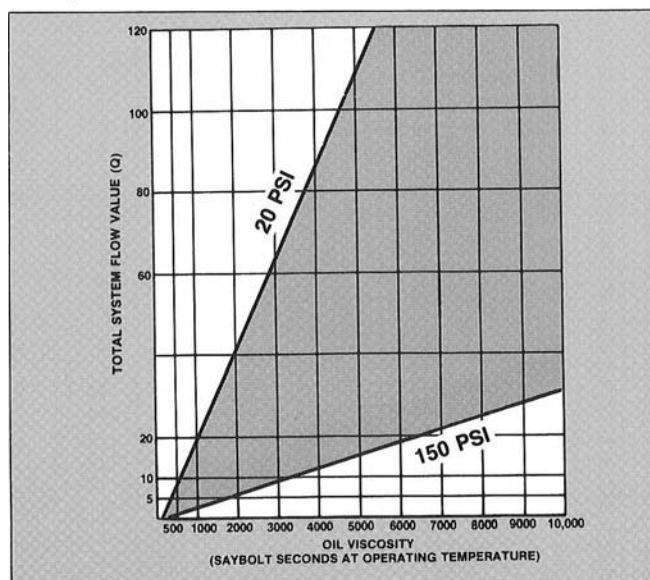

Design Chart C: Orifice Selection

Columns A-1 are Max:Min Base Ratios

Orifice Size	A	B	C	D	E	F	G	H	I	Flow Value
	Max:Min 512:-:1	256:1	128:1	64:1	32:1	16:1	8:1	4:1	2:1	
5/0	1	—	—	—	—	—	—	—	—	0.018
4/0	2	1	—	—	—	—	—	—	—	0.037
3/0	4	2	1	—	—	—	—	—	—	0.074
2/0	8	4	2	1	—	—	—	—	—	0.153
0	16	8	4	2	1	—	—	—	—	0.305
1	32	16	8	4	2	1	—	—	—	0.612
2	64	32	16	8	4	2	1	—	—	1.219
3	128	64	32	16	8	4	2	1	—	2.443
4	256	128	64	32	16	8	4	2	1	4.876
5	512	256	128	64	32	16	8	4	2	9.752

Design Chart E:

APPROXIMATE SSU OIL VISCOSITIES FOR SAE NUMBER SYSTEM AT VARIOUS TEMPERATURES (°F)						
	50°	60°	70°	80°	100°	210°
SAE 70	17,000	10,000	6,500	4,000	1,850	130
SAE 60	11,500	7,000	4,500	3,000	1,400	110
SAE 50	8,500	4,600	3,000	2,000	985	90
SAE 40	4,700	3,000	1,900	1,350	680	75
SAE 30	3,100	2,000	1,350	950	490	65
SAE 20	2,000	1,300	900	650	350	57
SAE 10	850	600	420	310	185	46



**Design Chart A**

CUSTOMER \_\_\_\_\_  
 MACHINE OR EQUIPMENT \_\_\_\_\_

TYPE OF SYSTEM: MANUAL  AUTOMATIC   
 OIL VISCOSITY \_\_\_\_\_ OPERATING TEMP. F° \_\_\_\_\_

FILE NO. \_\_\_\_\_  
 DATE \_\_\_\_\_  
 PAGE \_\_\_\_ OF \_\_\_\_

REF. NO.	1	2 BEARING		3	4	5	6	7	8	9	0						
		LOCATION OR NAME OF BEARING	SIZE (A)									TYPE (B)	NO. OF TAPS	BRG. REQ. CU.IN./HR.	FACTOR	LUBE VOLUME CU.IN./HR. (D)	LUBE VOLUME PER TAP (E)
1					3												
2					3												
3					3												
4					3												
5					3												
6					3												
7					3												
8					3												
9					3												
10					3												
11					3												
12					3												
13					3												
14					3												
<b>SYSTEM TOTAL</b>											—	—	—	—	—	—	THIS NO. EQUALS Q

- (A) DIAMETER WIDTH OF CYLINDRICAL BEARINGS - LENGTH AND WIDTH OF SLIDES - SHAFT DIAMETER OF ANTI-FRICTION BEARINGS AND NUMBER OF ROWS.
- (B) TYPE OF SURFACE - SLIDING, PLAN OR TYPE OF ANTI-FRICTION BEARING
- (C) FROM CHART "C"
- (D) BEARING REQUIREMENT X NUMBER OF TAPS X FACTOR (3)
- (E) LUBE SUPPLY VOLUME + NUMBER OF TAPS

© 2006 Graco Inc. Printed in U.S.A.

GRACO, INC. 18901 Cranwood Pkwy, Cleveland Ohio 44128 216-581-2000 (OHIO) FAX 216-581-3945 1-800-USA-LUBE

$P = \text{PRESSURE PSI}$   
 $F = \text{PUMP FLOW}$   
 $V = \text{OIL VISCOSITY}$   
 $Q = \text{TOTAL FLOW VALUE}$   
 $P = \frac{FXV}{Q}$

# Thrif-T Luber Orifice System Components

## INDEX

Part Number	Catalog Page	Part Number	Catalog Page	Model Number	Catalog Page	Model Number	Catalog Page
384-000-000	3	464-020-040	7	TLAB-00	9	TLOB-4	7
400-132-060	8	464-020-050	7	TLBF-00	9	TLOB-5	7
435-380-080	9	464-030-000	7	TLCF-00	9	TLOB-20	7
435-390-070	9	464-030-001	7	TLCN-00	9	TLOB-30	7
435-702-267	9	464-030-002	7	TLCP-00	9	TLOB-40	7
435-702-268	9	464-030-003	7	TLIF-00	9	TLOB-50	7
435-710-010	8	464-030-004	7	TLEP-10	4	TLOC-0	7
435-710-020	8	464-030-005	7	TLEP-11	4	TLOC-1	7
435-710-030	8	464-030-020	7	TLLF-00	8	TLOC-2	7
435-710-040	8	464-030-030	7	TLMP-00	3	TLOC-3	7
464-010-000	7	464-030-040	7	TLMB-04	9	TLOC-4	7
464-010-001	7	464-030-050	7	TLMB-06	9	TLOC-5	7
464-010-002	7	464-100-100	9	TLMB-08	9	TLOC-20	7
464-010-003	7	473-000-232	8	TLMB-10	9	TLOC-30	7
464-010-004	7	482-000-347	9	TLOA-0	7	TLOC-40	7
464-010-005	7	482-000-348	9	TLOA-1	7	TLOC-50	7
464-010-020	7	482-000-351	9	TLOA-2	7	TLPG-00	4, 8
464-010-030	7	482-000-353	9	TLOA-3	7	TLTC-01	8
464-010-040	7	482-000-355	9	TLOA-4	7	TLTC-02	8
464-010-050	7	482-00-357	9	TLOA-5	7	TLTC-03	8
464-020-000	7	493-020-199	4, 8	TLOA-20	7	TLTC-04	8
464-020-001	7	521-500-650	4	TLOA-30	7	TLTF-00	9
464-020-002	7	521-500-720	4	TLOA-40	7	TLTP-25	8
464-020-003	7	521-500-840	4	TLOA-50	7		
464-020-004	7	521-500-930	4	TLOB-0	7		
464-020-005	7	541-603-002	4	TLOB-1	7		
464-020-020	7	572-142-590	4	TLOB-2	7		
464-020-030	7			TLOB-3	7		

All written and visual data contained in this document are based on the latest product information available at the time of publication. Graco reserves the right to make changes at any time without notice.

Call today for product information or to request a demonstration.

**1.800.USA.LUBE** (1-800-872-5823) or visit us at [www.lubriquip.graco.com](http://www.lubriquip.graco.com).

©2006 Graco Inc. Bulletin TL-400, August 2006. Printed in U.S.A.

All other brand names or marks are used for identification purposes and are trademarks of their respective owners.

